

Spec sheet - meeting room for 2 people

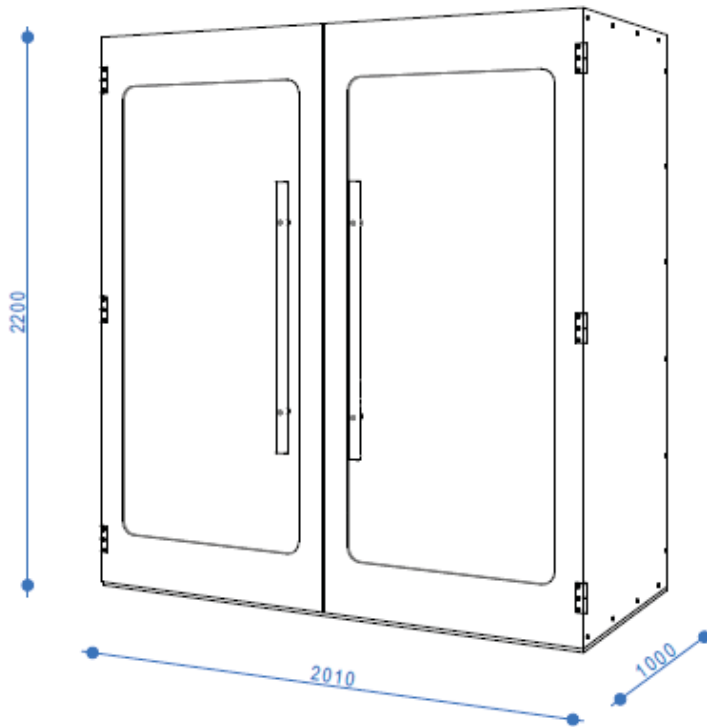

External dimensions	220 x 201 x 96 (cm) (height x width x depth)
Weight	580 kg
Interior and exterior walls material:	felt, 3 mm thick
Sound insulation	30 dB
Colour options:	light or dark colour option or extra colours of the felt paid additionally
INTERNAL ELEMENTS	
Ventilation	8 x silent fans with a total air flow of 990 m ³ /h (four in the ceiling and four in the floor), automatically activated by a motion detector, adjustable by a convenient knob
Table and seats	Table with dimensions of 82 x 60 cm mounted at a height of 74 cm; made of oak plywood; seats with dimensions: 79 x 44 x 45 cm, upholstered with 5 cm thick foam
Lighting	LED lighting is switched on automatically on motion detector
Glass doors with a magnetic locking system	doors made of 8 mm tempered glass; handle made of ash wood in the colour of natural oak
Sockets	2 x power sockets 230 V + 2 x USB sockets

100% OF CONCENTRION, 0% OF NOISE
Comfortable, modular meeting room for 2 people. It doesn't take up much space and fits into any office interior. Provides perfect conditions for meetings, phone calls or videoconferences and performing tasks that require concentration.

PERFECT MUTE

Multilayer walls filled with an acoustic sponge and covered with felt provide excellent noise insulation at 30 dB.

MODULAR CONSTRUCTION

Patented modular construction provides easy and quick assmebly of the meeting room. It can be disassembled just as quickly in case of moving or renovation.

COLOUR OPTIONS

- light: white enamel at the door + light gray felt on the external and internal walls + light gray upholstery on the seats + shelf in natural oak colour + handle in natural oak colour
- dark: black enamel at the door + dark gray felt on the external and internal walls + dark gray upholstery on the seats + shelf in natural oak colour + handle in natural oak colour
- additional options: 20 colours of standard felt or 38 colours of natural wool felt (at extra charge)

Witteveen Projectinrichting, Ouderkerk a/d Amstel
Tel: 020 - 496 5030 info@witteveen.nl
www.telefooncel.info www.project-inrichting.nl