

Assembly Instructions

When using a Humanscale work surface with pre-drilled metal inserts

Parts Required

- A. (1) Float Table Base
- B. (2) Float Wing Brackets
- C. (2) Float Feet
- D. (1) Mounted or Removable Spring Tension Adjuster
- E. (1) Mounted Spring Tension Adjuster Plastic Housing
- F. (12) M6 Short Machine Screws
- G. (4) M5 Long Machine Screws
- H. (4) M6 Short Flat Head Machine Screws
- I. (8) M8 Long Machine Screws
- J. (4) M5 Short Machine Screws
- K. (1) Safety Leg Pin

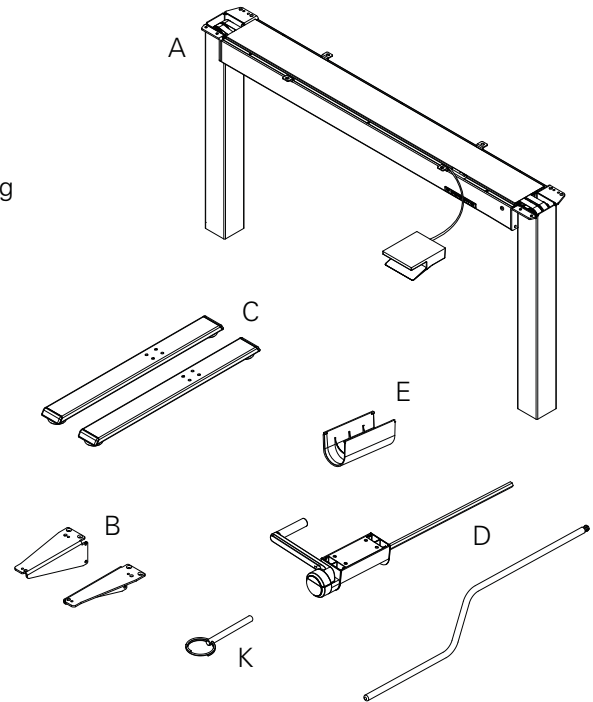

Tools Required

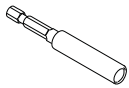

Extension Hex Drive



Power Drill



5/32 " Hex Drive



3/16 " Hex Drive



3 mm Hex Drive

Hardware Bag

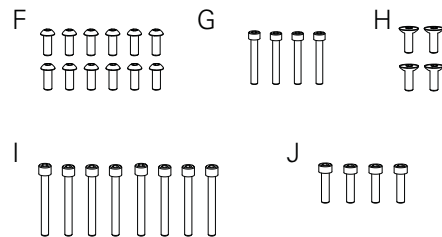

Assembly Instructions for Humanscale pre-drilled work surfaces

1 Installing the Float Wing Brackets

- Remove the two machine screws on each end of the center beam (fig. A)

Important: The machine screws that should be removed are the ones on the same side as the spring tension min – max scale

- Install each Bracket on its respective table side by screwing the two machine screws through the Wing Bracket and back into the center beam (fig. B)
- Install the (4) M6 Short Flat Head Machine Screws through the top of the Wing Brackets and into the Float Base (fig. C)

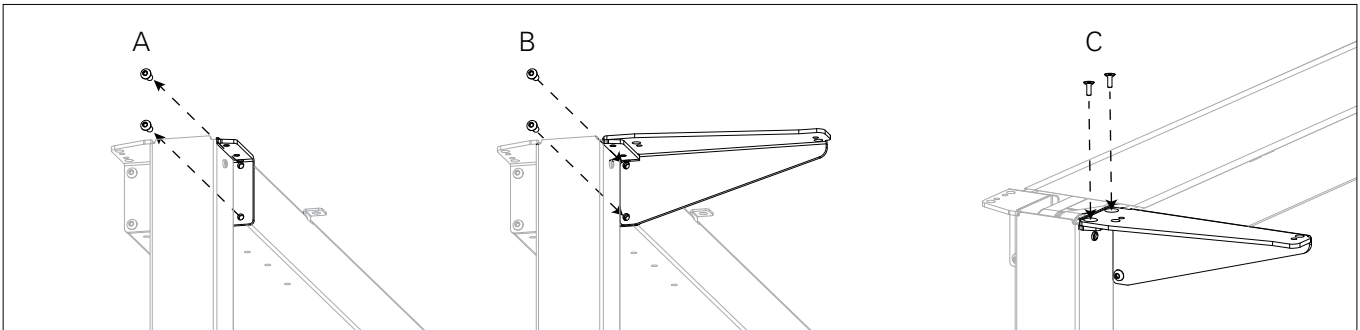

2 Installing the Float Feet

- Turn the Float Base upside down so that the center beam is on the floor while the Float Feet are being installed
- Install the Feet by lining up each of the four holes over the top of the legs

Important: The longer section of the Feet must be on the same side as the spring tension min – max scale

- Use (4) M8 Long Machine Screws to secure each Foot to the Base frame (fig. D)

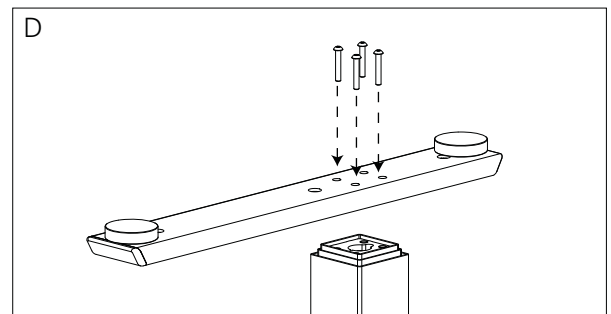

3 Place the work surface face down on a soft surface to avoid scratching it

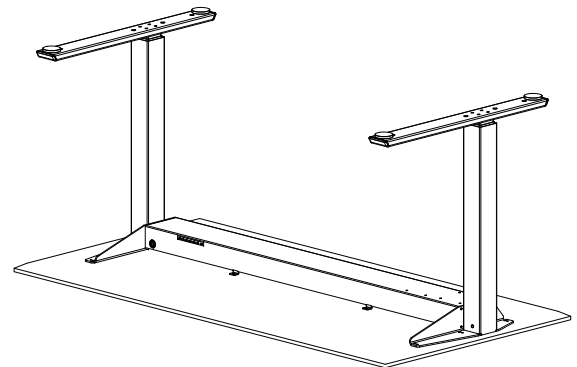

4 Turn the Float Base upside down (if it is not already) and place onto the underside of the work surface

- Ensure that all mounting holes on the Float Base line up with the pre-drilled metal inserts on the underside of the work surface
- With the Float Base in position, use the (12) M6 Short Machine Screws to secure the Float Base to the work surface (fig. E)

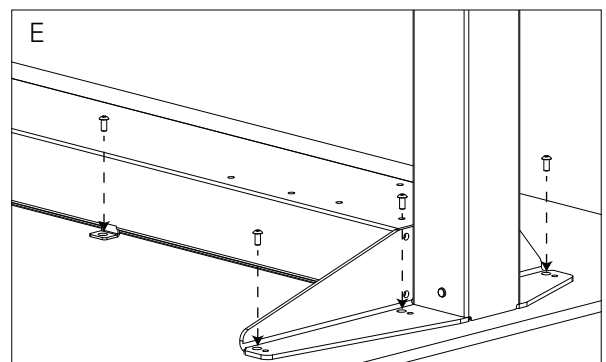

5 Installing the Release Paddle

- Line up the Release Paddle with the corresponding pre-drilled metal inserts on the underside of the work surface
- With the Release Paddle in position, use the (4) M5 Long Machine Screws to secure the Release Paddle to the work surface (fig. F)

Important: Do not over tighten the Release Paddle

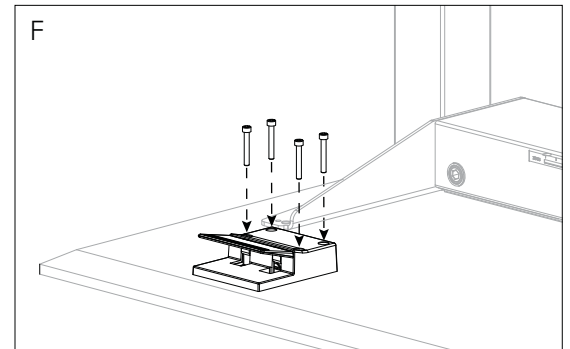

6 Installing the Mounted Spring Tension Adjuster

(if you did not order your Float with this option, please proceed to step 7)

- Take the Mounted Spring Tension Adjuster and locate the metal shaft into the hex spigot on the center beam
- Line up the Mounted Spring Tension Adjuster with the corresponding pre-drilled metal inserts on the underside of the work surface
- With the Mounted Spring Tension Adjuster in position, use the (4) M5 Short Machine Screws to secure it to the work surface
- Take the Mounted Spring Tension Adjuster Plastic Housing, place and snap into position over the (4) M5 Short Machine Screws that were installed in step 6c (fig. G)

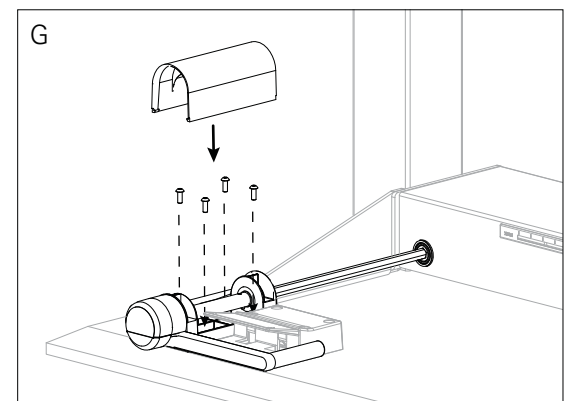

7 Carefully turn the Float back over and into position so that it is ready to use

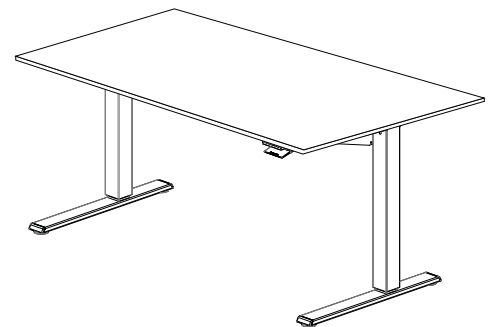

8 Remove the Safety Leg Pin on the right side (to the right of the min – max scale) by removing the red tape and pulling it out (this is used for shipping purposes only) (fig. H)

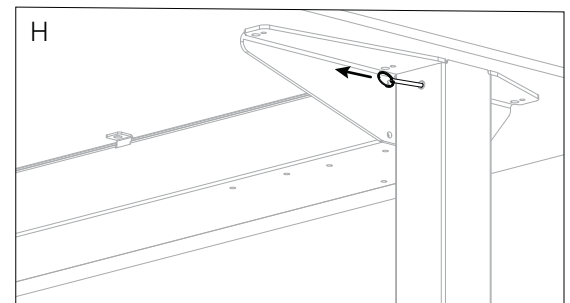

9 You will now be able to operate your new Float by gently squeezing the Release Paddle and supporting the work surface as you raise and lower it

Adjusting Float

- 1 If you are finding it difficult to raise and lower your Float, please check the barrel adjuster behind the back of the Release Paddle (fig. A). The barrel adjuster needs to be adjusted to increase the tension in the Release Paddle which will allow for the Float to easily raise and lower. To make the required adjustment, simply turn the barrel adjuster counterclockwise until you have between $\frac{3}{4}$ " and $\frac{1}{2}$ " of metal thread showing. You will now find that the Release Paddle will engage better and allow for the Float to be raised and lowered

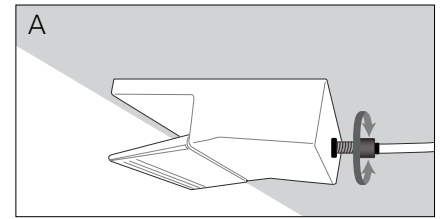

Important: Please be aware that your newly purchased Float will hold a maximum weight of 130 lbs. Please contact Customer Service if you would like to find out more information about our Float heavy duty kit that will increase the maximum weight loading from 130 lbs to 160 lbs.

- 2 **Adding Weight to the Work Surface (fig. B)**
As you begin to add more weight to the work surface, it will become more difficult to raise and lower the table. The following steps explain how to adjust your Float to make it easier to raise and lower:

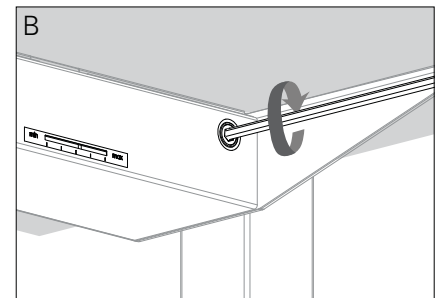

1. Squeeze the Release Paddle and raise the work surface to its maximum height (fully extended)
2. If using the Removable Spring Tension Adjuster, insert it into the hex spigot on the center beam to the right of the min – max scale
3. Using either the Removable or Mounted Spring Tension Adjuster, slowly begin to increase the tension by turning the Adjuster clockwise
4. You will start to see the red mark on the min – max scale move from the min mark towards the max mark
5. Once you have adjusted your Float, bring the work surface back down and try raising and lowering it a few times until it fluidly adjusts
6. If you need to make further adjustments, raise the Float to its maximum height and follow these steps again

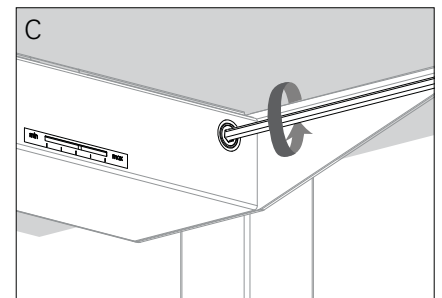

Removing Weight from the Work Surface (fig. C)

As you begin to remove weight from your work surface, you will notice that Float will raise quickly and be difficult to lower. Simply follow the above instructions about adding weight to the work surface, but instead of turning the Adjuster clockwise, you will need to turn the Adjuster counterclockwise to release the spring tension in the Float.

- 3 Float sits on four glides which can be adjusted to level the work surface, if the floor is not level. These can be independently adjusted.

Troubleshooting Float

- 1 If you are finding it difficult to raise and lower your Float, please check the barrel adjuster behind the back of the Release Paddle (fig. A). The barrel adjuster needs to be adjusted to increase the tension in the Release Paddle which will allow for the Float to raise and lower. To make the required adjustment, simply turn the barrel adjuster counterclockwise until you have between $\frac{3}{4}$ " and $\frac{1}{2}$ " of metal thread showing. You will now find that the Release Paddle will engage better and allow for the Float to be raised and lowered
- 2 If your Float is adjusted so that the min – max mark is at the $\frac{3}{4}$ " position on the scale and the Float is still very difficult to raise and lower, please contact Customer Service who will help you order a heavy duty Float kit that will allow for the weight limit to be increased from 130 lbs to 160 lbs. This heavy duty kit will make the table easier to adjust with the additional weight.

Assembly Instructions

When using your own work surface that is at least 3/4 " thick and has no pre-drilled holes

Parts Required

- A. (1) Float Table Base
- B. (2) Float Wing Brackets
- C. (2) Float Feet
- D. (1) Mounted or Removable Spring Tension Adjuster
- E. (1) Mounted Spring Tension Adjuster Plastic Housing
- F. (12) 3/4 " Wood Screws
- G. (4) 1 1/2 " Wood Screws
- H. (4) M6 Short Flat Head Machine Screws
- I. (8) M8 Long Machine Screws
- J. (4) 1/2 " Wood Screws
- K. (1) Safety Leg Pin

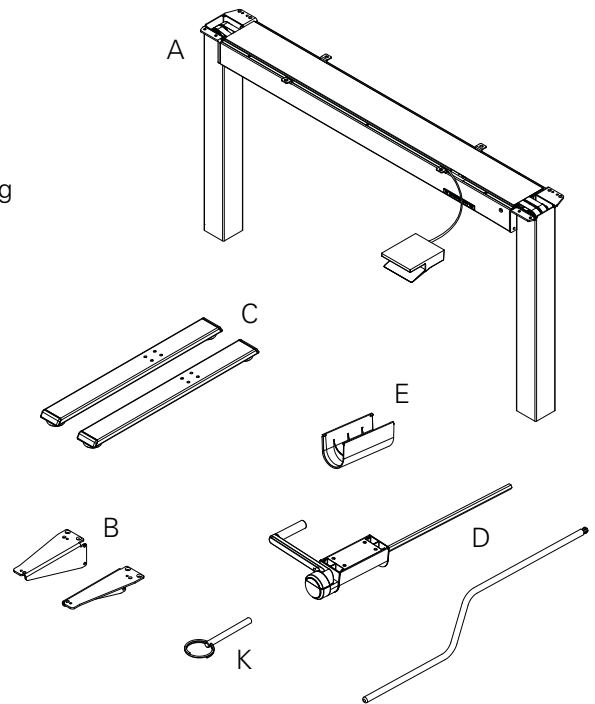

Tools Required

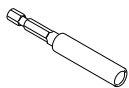

Extension Hex Drive



Pencil



5/32 " Hex Drive

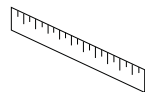

Ruler



3/16 " Hex Drive



Power Drill



#2 Phillips Screwdriver

Hardware Bag

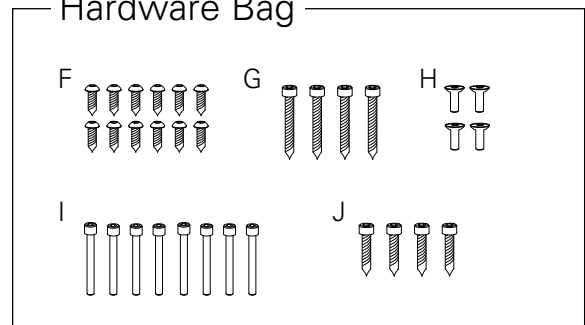

Assembly Instructions for work surfaces with no pre-drilled holes

1 Installing the Float Wing Brackets

- Remove the two machine screws on each end of the center beam (fig. A)

Important: The machine screws that should be removed are the ones on the same side as the spring tension min – max scale

- Install each Bracket on its respective table side by screwing the two machine screws through the Wing Bracket and back into the center beam (fig. B)
- Install the (4) M6 Short Flat Head Machine Screws through the top of the Wing Brackets and into the Float Base (fig. C)

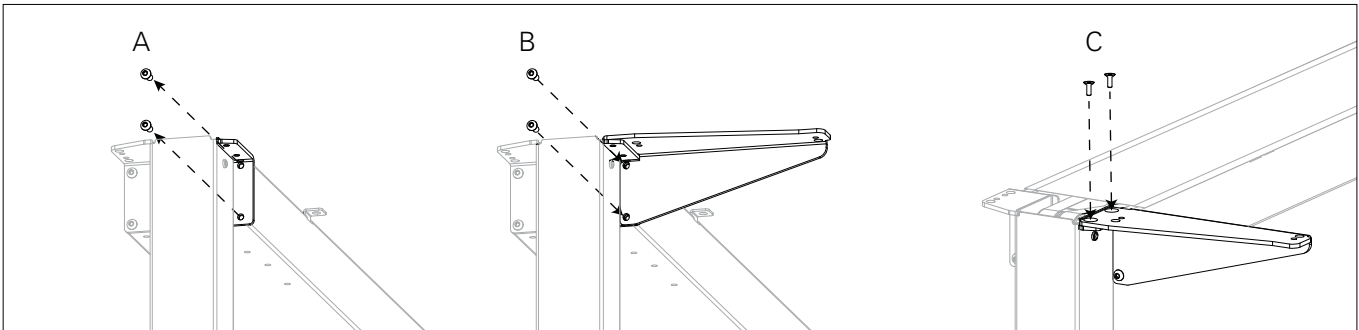

2 Installing the Float Feet

- Turn the Float Base upside down so that the center beam is on the floor while the Float Feet are being installed
- Install the Feet by lining up each of the four holes over the top of the legs

Important: The longer section of the Feet must be on the same side as the spring tension min – max scale

- Use (4) M8 Long Machine Screws to secure each Foot to the Base frame (fig. D)

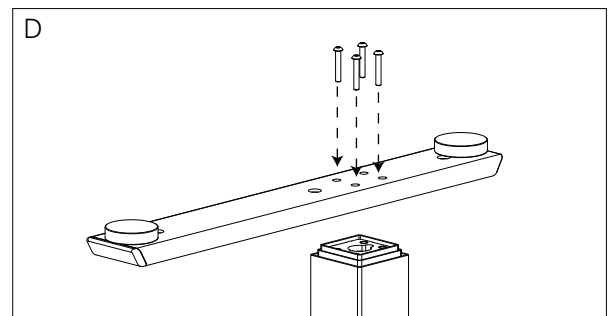

3 Place the work surface face down on a soft surface to avoid scratching it

4 Turn the Float Base upside down (if it is not already) and place onto the underside of the work surface

- Please ensure that the Float Base is centered so that there is equal distance from the edge of the work surface on either side

For Float tables that have 30" deep surfaces: Measure and mark 16.5" from the front edge of the work surface to the front edge of the center beam (the same edge that the spring min – max scale is positioned on) (example shown)

For Float tables that have 24" deep surfaces: Measure and mark 13.5" from the front edge of the work surface to the front edge of the center beam (the same edge that the spring min – max scale is positioned on)

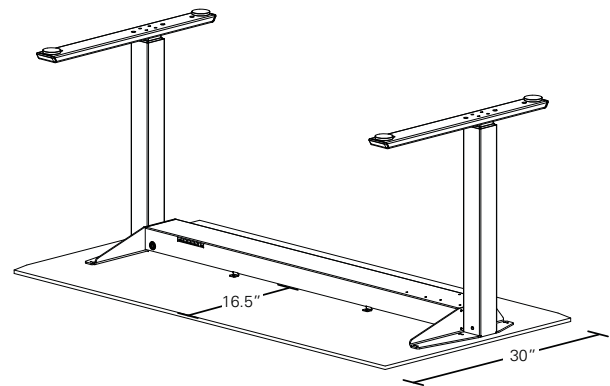

5 With the Float Base in position according to your markings, use the (12) 3/4" Wood Screws to secure the Float Base to the work surface. Use the smaller holes provided on the Float Base for this (fig. E)

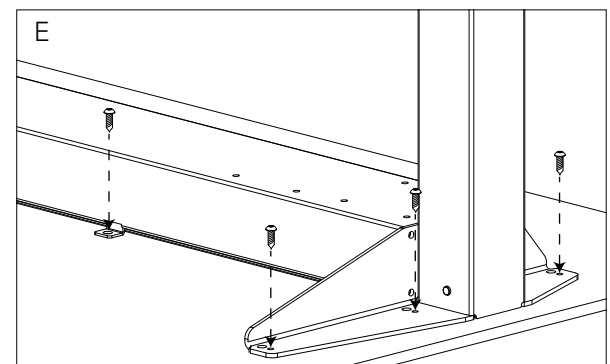

6 Installing the Release Paddle

- Place the Float Release Paddle 1" from the front edge of the work surface and 2¼" from the inside edge of the Wing Bracket (fig. F)
- Use the (4) 1½" Wood Screws to secure the Release Paddle to the work surface. (fig. G)

Important: Do not over tighten the Release Paddle

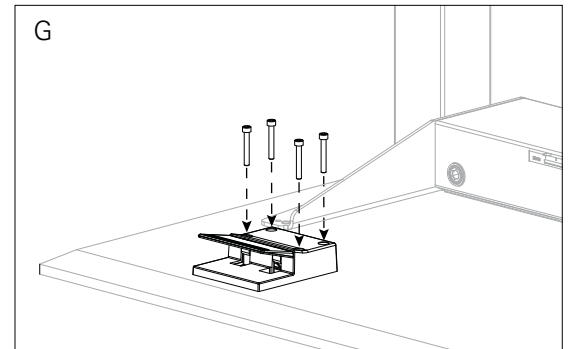
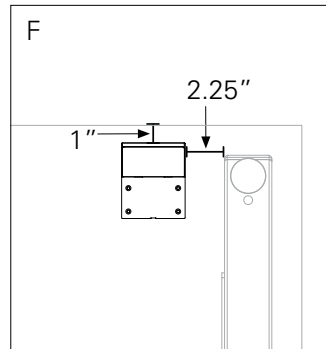

7 Installing the Mounted Spring Tension Adjuster

(if you did not order your Float with this option, please proceed to step 8)

- Take the Mounted Spring Tension Adjuster and locate the metal shaft into the hex spigot in the center beam
- Position the Mounted Spring Tension Adjuster in line with the installed Release Paddle. Use the (4) ½" Wood Screws to secure down to the work surface
- Take the Mounted Spring Tension Adjuster Plastic Housing, place and snap into position over the (4) ½" Wood Screws that were installed in step 7b (fig. H)

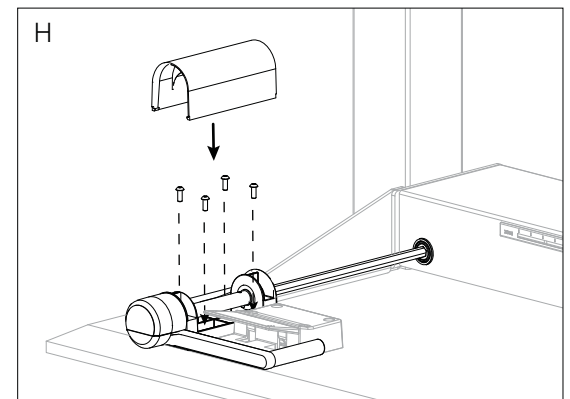

8 Carefully turn the Float back over and into position so that it is ready to use

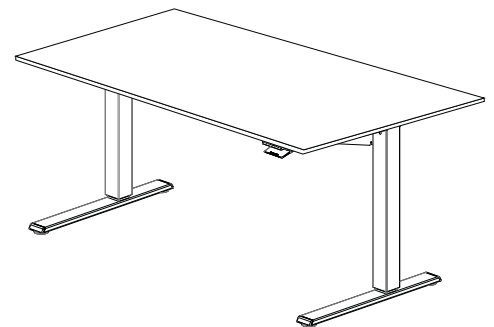

9 Remove the Safety Leg Pin on the right side (to the right of the min – max scale) by removing the red tape and pulling it out (this is used for shipping purposes only) (fig. I)

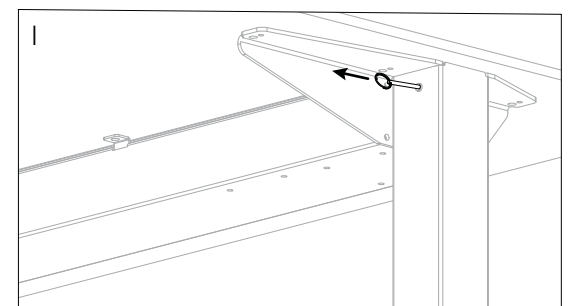

10 You will now be able to operate your new Float by gently squeezing the Release Paddle and supporting the work surface as you raise and lower it

Adjusting Float

- 1 If you are finding it difficult to raise and lower your Float, please check the barrel adjuster behind the back of the Release Paddle (fig. A). The barrel adjuster needs to be adjusted to increase the tension in the Release Paddle which will allow for the Float to easily raise and lower. To make the required adjustment, simply turn the barrel adjuster counterclockwise until you have between $\frac{3}{4}$ " and $\frac{1}{2}$ " of metal thread showing. You will now find that the Release Paddle will engage better and allow for the Float to be raised and lowered

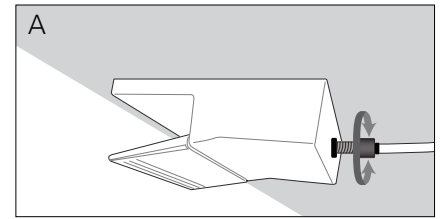

Important: Please be aware that your newly purchased Float will hold a maximum weight of 130 lbs. Please contact Customer Service if you would like to find out more information about our Float heavy duty kit that will increase the maximum weight loading from 130 lbs to 160 lbs.

- 2 **Adding Weight to the Work Surface (fig. B)**
As you begin to add more weight to the work surface, it will become more difficult to raise and lower the table. The following steps explain how to adjust your Float to make it easier to raise and lower:

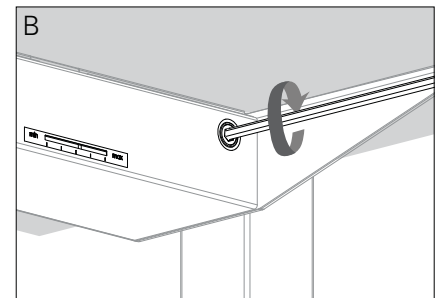

1. Squeeze the Release Paddle and raise the work surface to its maximum height (fully extended)
2. If using the Removable Spring Tension Adjuster, insert it into the hex spigot on the center beam to the right of the min – max scale
3. Using either the Removable or Mounted Spring Tension Adjuster, slowly begin to increase the tension by turning the Adjuster clockwise
4. You will start to see the red mark on the min – max scale move from the min mark towards the max mark
5. Once you have adjusted your Float, bring the work surface back down and try raising and lowering it a few times until it fluidly adjusts
6. If you need to make further adjustments, raise the Float to its maximum height and follow these steps again

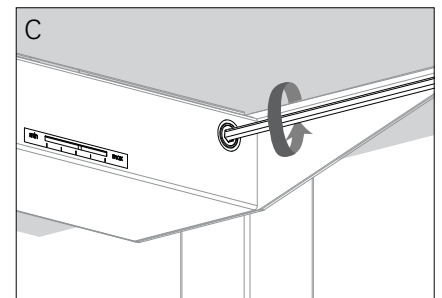

Removing Weight from the Work Surface (fig. C)

As you begin to remove weight from your work surface, you will notice that Float will raise quickly and be difficult to lower. Simply follow the above instructions about adding weight to the work surface, but instead of turning the Adjuster clockwise, you will need to turn the Adjuster counterclockwise to release the spring tension in the Float.

- 3 Float sits on four glides which can be adjusted to level the work surface, if the floor is not level. These can be independently adjusted.

Witteveen Projectinrichting
Ouderkerk a/d Amstel
Tel: 020 - 496 5030
Fax: 020 - 496 3052
info@witteveen.nl
www.project-inrichting.nl
www.staand-werken.nl

Troubleshooting Float

- 1 If you are finding it difficult to raise and lower your Float, please check the barrel adjuster behind the back of the Release Paddle (fig. A). The barrel adjuster needs to be adjusted to increase the tension in the Release Paddle which will allow for the Float to raise and lower. To make the required adjustment, simply turn the barrel adjuster counterclockwise until you have between $\frac{3}{4}$ " and $\frac{1}{2}$ " of metal thread showing. You will now find that the Release Paddle will engage better and allow for the Float to be raised and lowered
- 2 If your Float is adjusted so that the min – max mark is at the $\frac{3}{4}$ " position on the scale and the Float is still very difficult to raise and lower, please contact Customer Service who will help you order a heavy duty Float kit that will allow for the weight limit to be increased from 130 lbs to 160 lbs. This heavy duty kit will make the table easier to adjust with the additional weight.