

Welcome to Ollin.



reddot design award
winner 2017





Ollin, our revolutionary monitor arm, supports the screen technology of today and helps the user prepare for the screen technology of the future.

Constantly shifting and morphing with each day, the world of business is never static. A productive workplace should reflect this in its ability to evolve with changing business requirements. Cloud computing and the use of hybrid laptop/tablets are shifting how and why computer screens are used, and as developments in technology increase, the need for the workplace to be more responsive has never been more relevant.

As business's adopt and adapt their workspace's to accommodate new technologies, Ollin is a solution that can grow and evolve with this changing technology in the modern workspace. Encouraging users to interact with technology and each other as seamlessly as possible.

SEE THE LIGHT

As technology advances, screens are becoming lighter and often more compact.

Ollin's unique technical cord supports weights from 0kg up to 9kg, helping business's stay in touch as technology advances, and screens become lighter and more mobile.

And as this trend continues, Ollin can grow and adapt to the latest technology.

TWO GOOD

As dual screen working becomes more prevalent in the workspace, Ollin's ability to be easily adapted offers a solution to support this shift in working styles. A dual screen mount can be attached to the main arm, and because there's no need to provide a separate arm for each screen, expenditure is kept to a minimum while productivity increases.

Ollin is a cost effective, future proofed solution to the changing configurations of modern workstations.

OLLIN DUAL



EASY CABLE MANAGEMENT SYSTEM



WEIGHT GAUGE INDICATOR



FLO POWERHUB COMPATIBLE

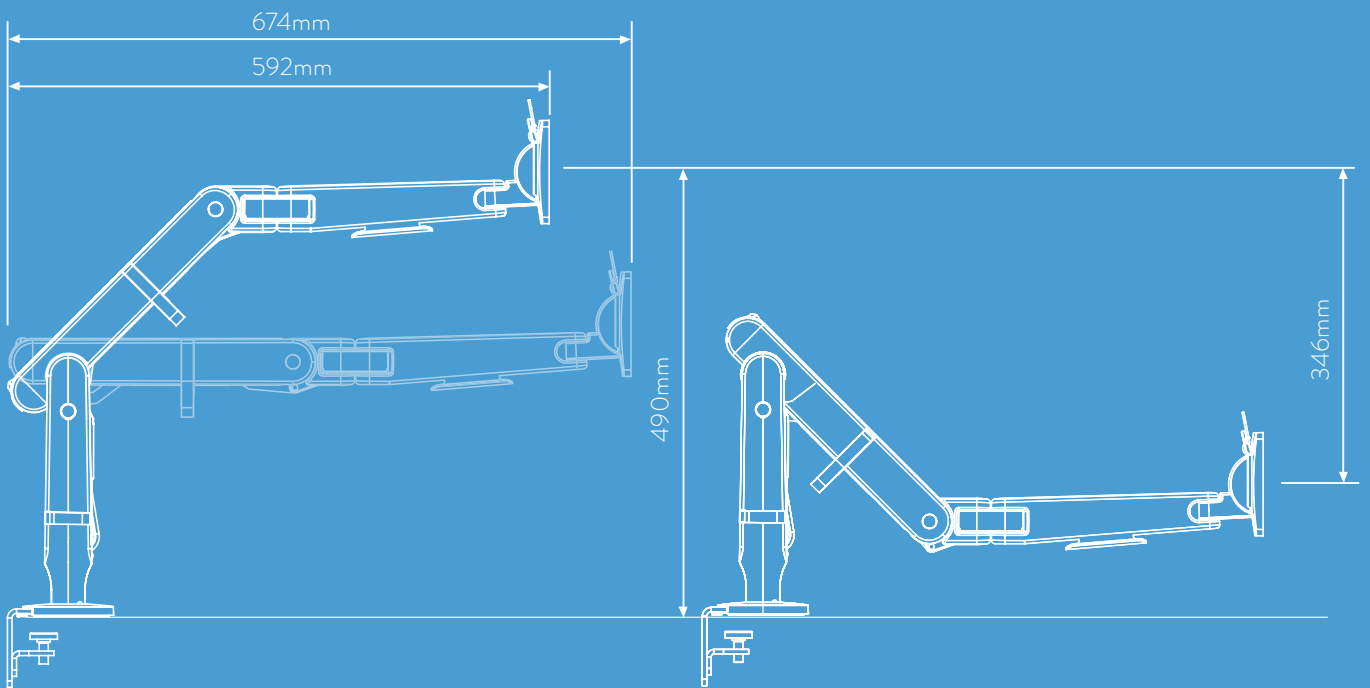

OVERVIEW

- Monitor weight range: 0 - 9kg
- Horizontal reach: 674mm (26.5")
- Vertical adjustment: 346mm (13.5")
- Monitor head: VESA 75 and 100 compliant
- 180° stop function/360° capability
- Suitable for multi-screens, laptops and tablets
- Available in white, silver and black



info@cbsproducts.co.uk
+44 (0)207 940 4266

www.colebrookbossonsaunders.com

Witteveen Projectinrichting
Ouderkerk a/d Amstel
Tel: 020 - 496 5030
info@witteveen.nl
www.ergonomics.nl
www.project-inrichting.nl

